

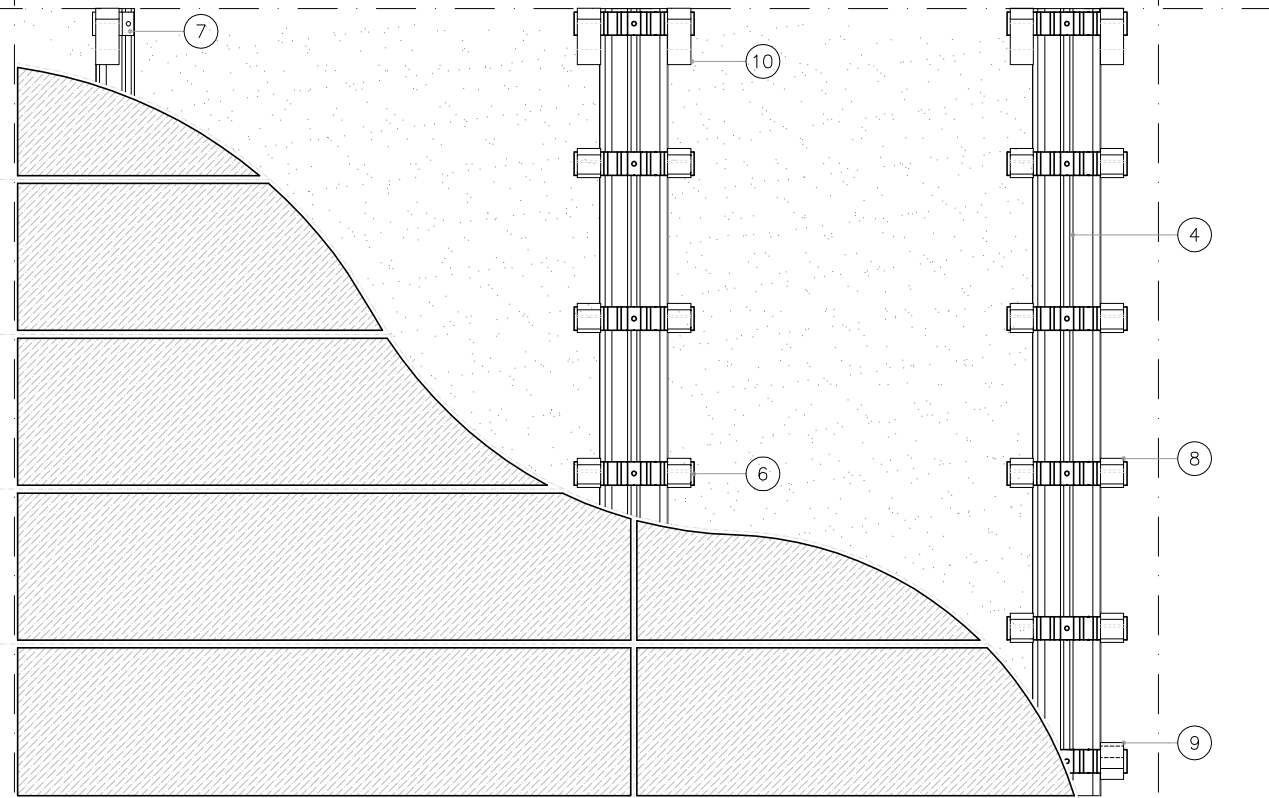

# TerraMODUS 200 System L (gap 170mm)

ESPLODED STRUCTURE

VERTICAL SECTION



FRONT VIEW

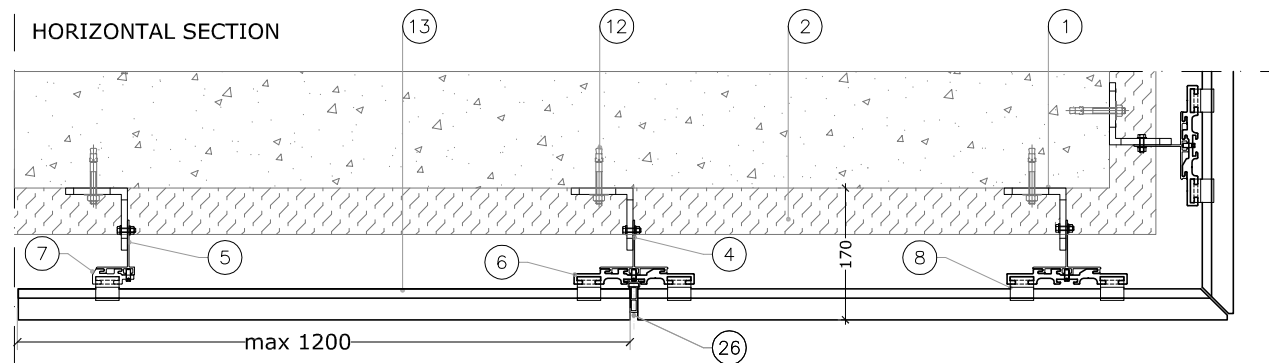

HORIZONTAL SECTION

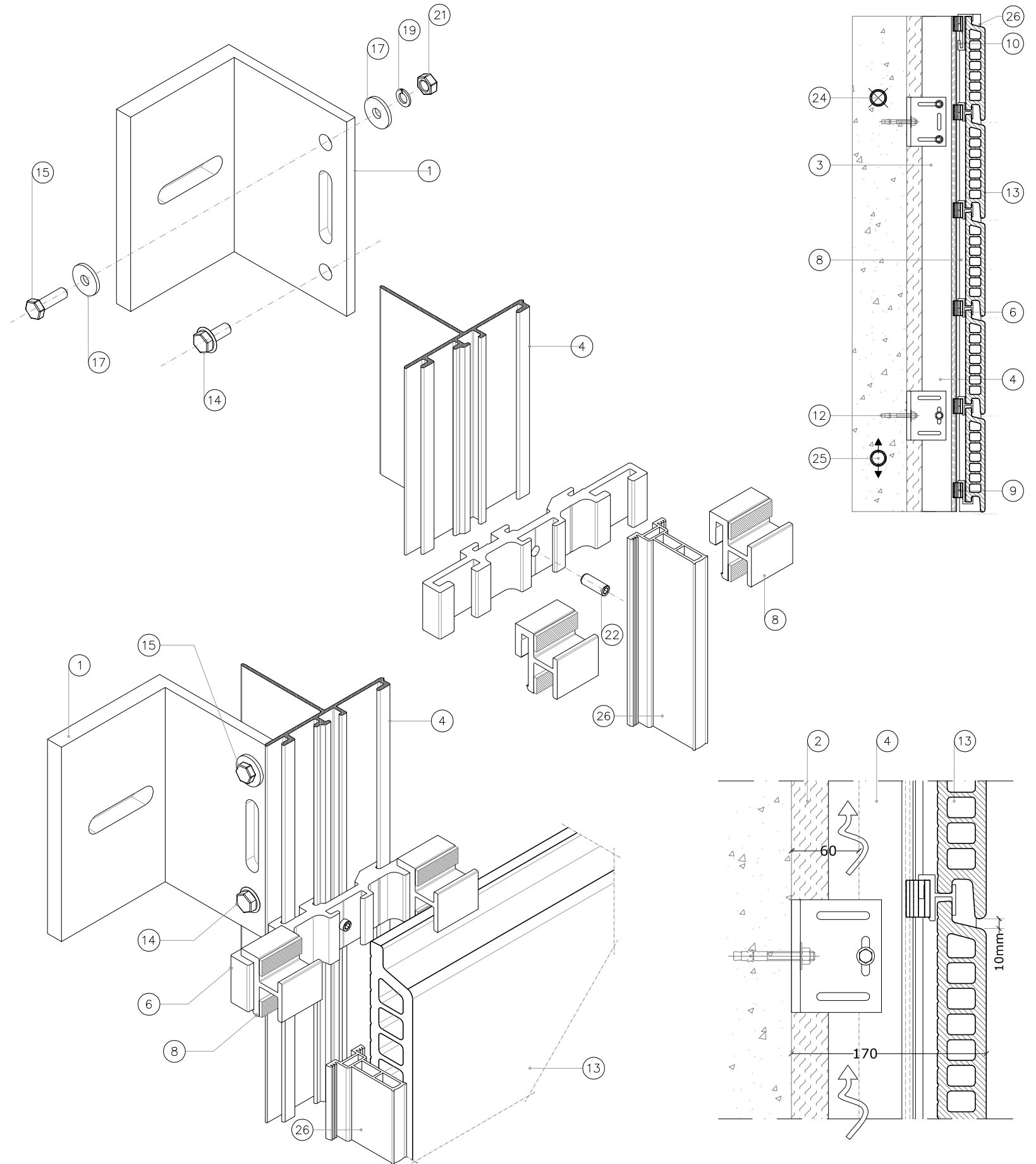

- |  |                                 |
|--|---------------------------------|
| ① Bracket L aluminium alloy 6005 A           | ⑭ Screw self-drilled TE 6,3x25  |
| ② Insulating material                        | ⑮ Screw M6x30 DIN 933 Inox A2   |
| ③ Ventilation chamber                        | ⑯ Washer 8x16 DIN 125 A Inox A2 |
| ④ Vertical Track VT3 aluminium alloy 6063 T6 | ⑰ Washer 6x18 DIN 9021 Inox A2  |
| ⑤ Vertical Track VT4 aluminium alloy 6063 T6 | ⑱ Grower M8 DIN 127 B Inox A2   |
| ⑥ Support S01 aluminium alloy 6005 A         | ⑲ Grower M6 DIN 127 B Inox A2   |
| ⑦ Support S02 aluminium alloy 6005 A         | ⑳ Nut M8 DIN 934 Inox A2        |
| ⑧ Clip TM1 aluminium alloy 6005 A            | ㉑ Nut M6 DIN 934 Inox A2        |
| ⑨ Clip TF1 aluminium alloy 6005 A            | ㉒ Screw DIN 916 6x16 Inox A2    |
| ⑩ Clip TF2 aluminium alloy 6005 A            | ㉓ Thick Neoprene                |
| ⑪ Bracket L10 aluminium alloy 6005 A         | ㉔ Fixed point symbol            |
| ⑫ Mechanical Fixing                          | ㉕ Free point symbol             |
| ⑬ Tile TerraModus 200                        | ㉖ EPDM Stripe G01               |

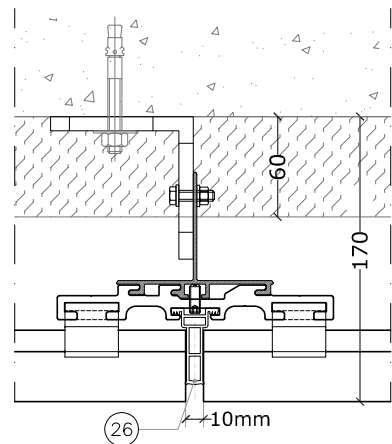

This drawing is the exclusive property of Palagio Engineering s.r.l. Reproduction in any form is strictly prohibited